

NOTE:

- DIM'S IN m.m.
- POT. READS 20.25

T1-MK2
1830.0 ELEV.

JAN 30, 2020

pg. 1 of 1

I. Earle

ENTRY

EXIT

ALL VIEWS DRAWN FROM PERSPECTIVE OF BEAM DIRECTION

POS'N #5
 SER.# JUL 07 #1
 New AUG 9/07

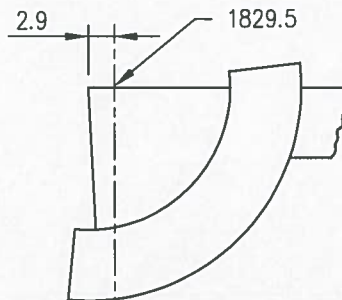
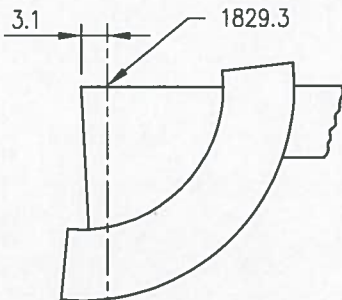

POS'N #4
 PLUGGED



POS'N #3
 SER.# 103
 New SEPT 2016

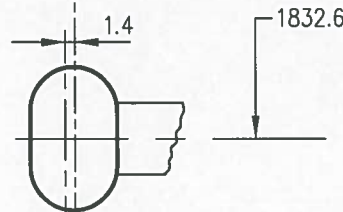
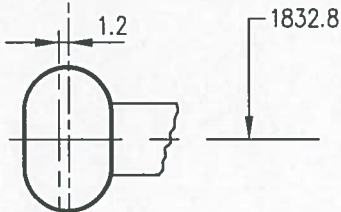

POS'N #2
 SER.# 102
 New SEPT 2016

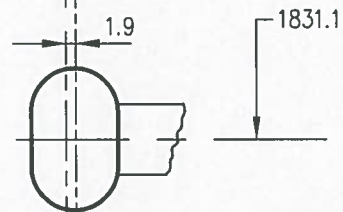
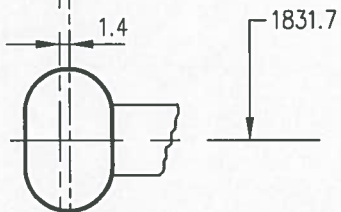

POS'N #1
 SER.# 105
 New JAN 2020

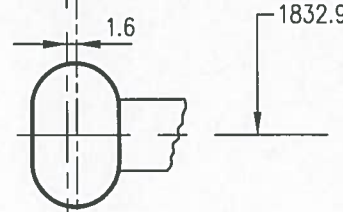
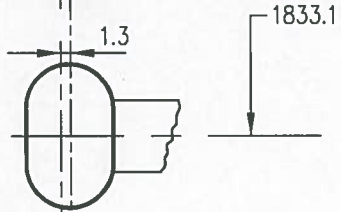

MEASUREMENT NOT POSSIBLE
 (OBSCURED BY PROTECT MON.)

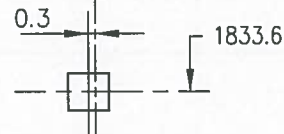
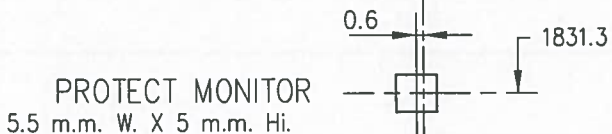
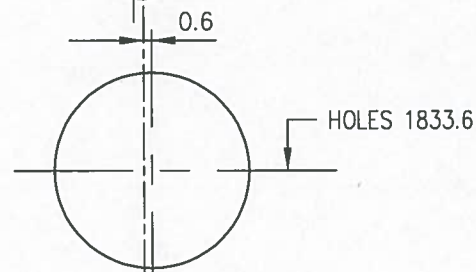
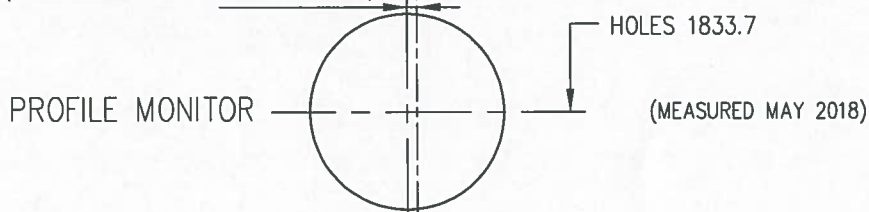

DESIGN CENTER OF BEAM