

Notes:

Dimensions are in inches, and are prior to plating.
 Diameters may be out of round in excess of tolerances.
 Material: AMS5596 Inconel 718
 Thickness: 0.010
 Treatment: Precipitation heat treated
 Plating Thickness: 0.0010/0.0015"

REVISIONS				
ZONE	REV	DESCRIPTION	DATE	APPROVED

Flange Groove Detail:

OD: 0.437 +0.001/-0.000
 ID: 0.262 max.
 Groove Depth: 0.073/0.077

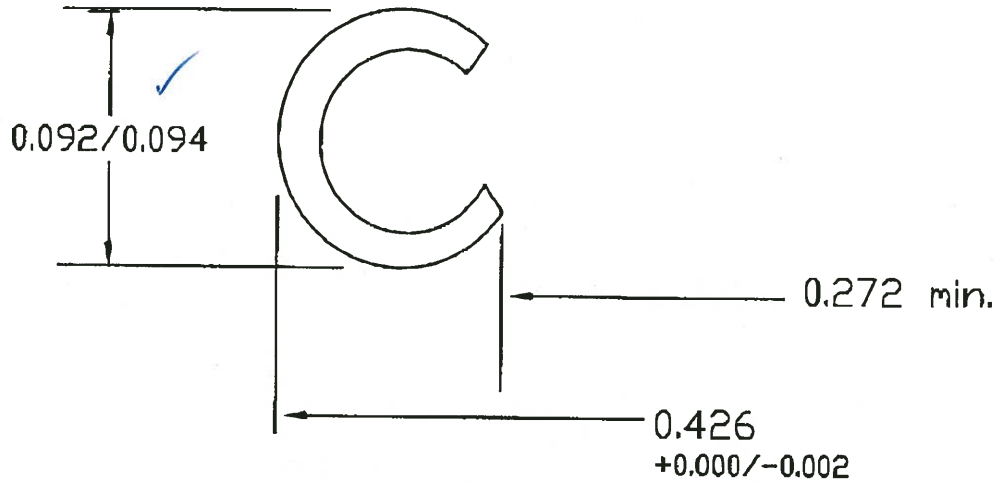

Ultra Seal P/N: SP 50531

Prepared For: TRIUMF(Canada)		Title: Metal C-Seal-Inside Pressure		
		Ultra Seal Rancho Cucamonga, CA		
Material: Inconel 718	SIZE: B	FORM NO.	DWG NO.	REV
Plating: Silver	SCALE: None		SHEET 1 OF 1	

Notes:
 Dimensions are in inches, and are prior to plating.
 Diameters may be out of round in excess of tolerances.
 Material: AMS5596 Inconel 718
 Thickness: 0.015
 Treatment: Precipitation heat treated
 Plating Thickness: 0.0025

REVISIONS				
ZONE	REV	DESCRIPTION	DATE	APPROVED

Flange Groove Detail:
 OD: 0.437 +0.001/-0.000
 ID: 0.262 max.
 Groove Depth: 0.073/0.077

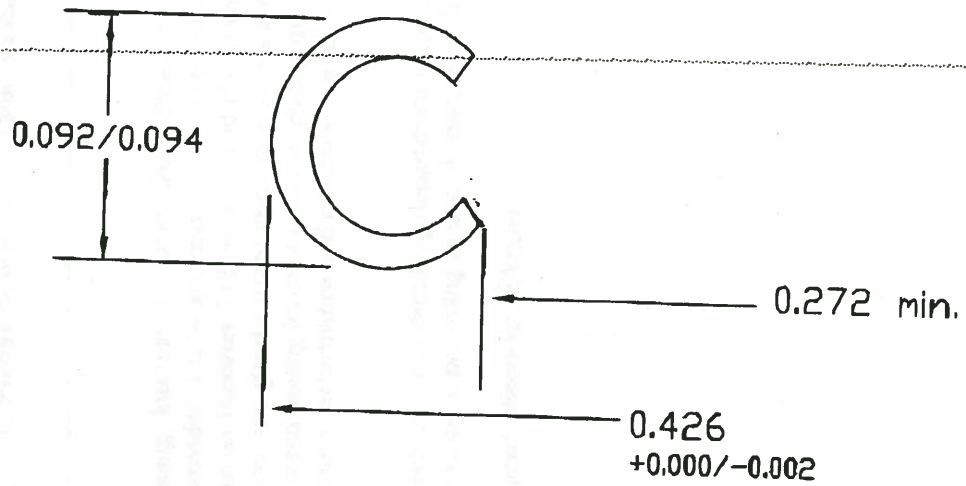

Ultra Seal P/N: SP 50606

Prepared For: TRIUMF(Canada)		Title: Metal C-Seal-Inside Pressure			
		Ultra Seal Corona, CA			
Material: Inconel 718	SIZE B	FORM NO.	DWG NO.		REV
Plating: Indium	SCALE None			SHEET 1 of 1	

Notes:
 Dimensions are in inches, and are prior to plating.
 Diameters may be out of round in excess of tolerances.
 Material: AMS5596 Inconel 718
 Thickness: 0.015
 Treatment: Precipitation heat treated
 Plating Thickness: 0.0025

REVISIONS				
ZONE	REV	DESCRIPTION	DATE	APPROVED

Flange Groove Detail:
 OD: 0.437 +0.001/-0.000
 ID: 0.262 max.
 Groove Depth: 0.073/0.077

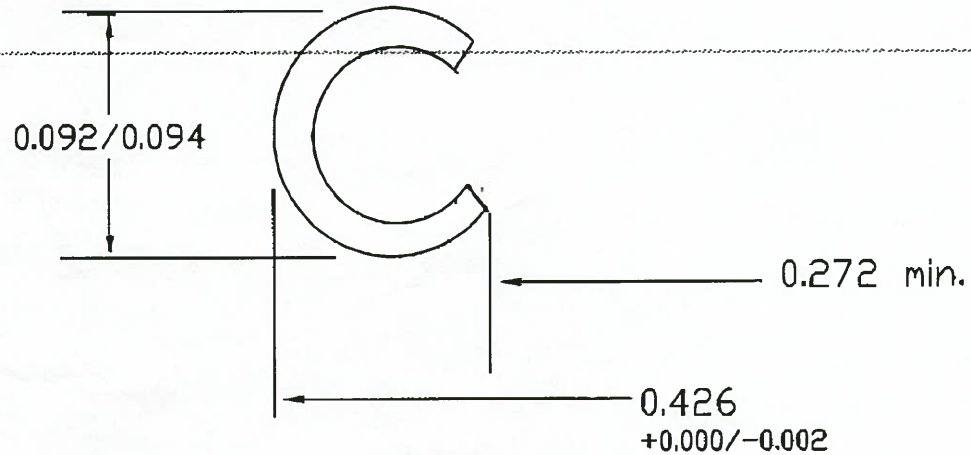

Ultra Seal P/N: SP 50606

Prepared For: TRIUMF(Canada)		Title: Metal C-Seal-Inside Pressure		
		Ultra Seal Corona, CA		
Material: Inconel 718	SIZE B	PSCH NO.	DWG NO.	REV
Plating: Indium	SCALE None			SHEET 1 of 1

GARLOCK HELICOFLEX

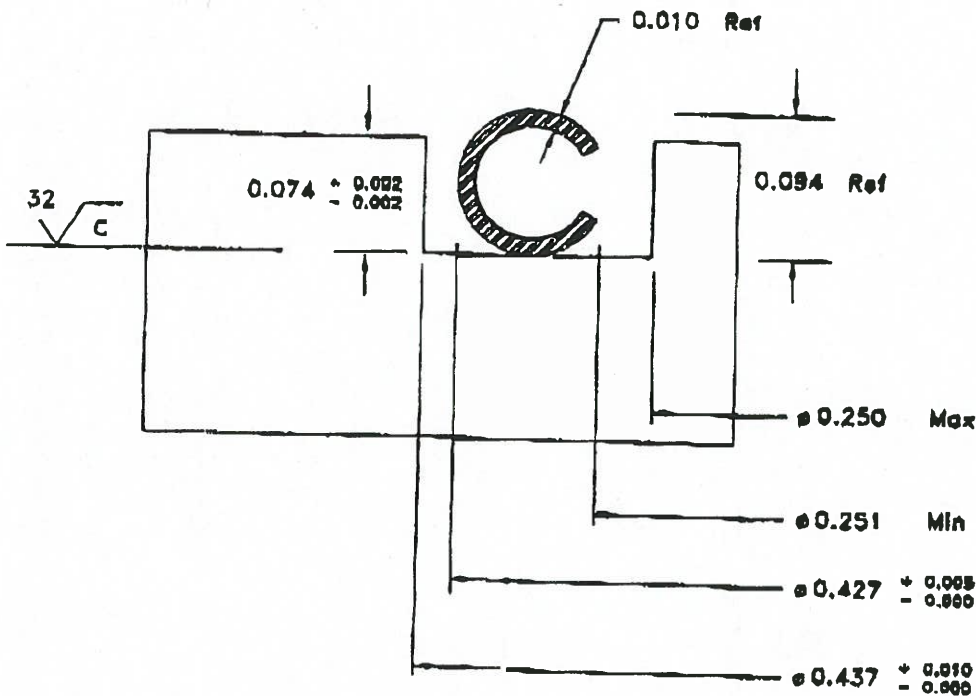

Seal Type METAL C-RING	Part Number: C-601481 REV NC	Base Material: ALLOY 718
Working Temperature: UNKNOWN	Seating Load: Y2 (lbs/inch) 226 LB/IN (250 LBS TOTAL)	Compression: e2 0.020"
Working/Proof Pressure: UNKNOWN	Media: UNKNOWN	Other: Plating INDIUM 0.001"/0.002" THICK
Customer Target Leak Rate: UNKNOWN	Scale: none Dimensions: inches Finish: micromches	



GARLOCK HELICOFLEX
2770 THE BLVD
COLUMBIA, SC 29290
PHONE: 803-783-1122
FAX: 803-783-4222

THIS DRAWING CONTAINS PROPRIETARY INFORMATION OF GARLOCK HELICOFLEX, AND IS PROVIDED FOR ENGINEERING EVALUATION AND/OR RECEIVING AND INSPECTION PURPOSES ONLY. IT HAS BEEN ENTRUSTED TO THE RECIPIENT WITH THE UNDERSTANDING THAT ITS USE WILL BE RESTRICTED TO SUCH PURPOSES. COPYING, TRACING AND OTHER TYPES OF REPRODUCTION FOR MANUFACTURING AND/OR COMPETITIVE PROCUREMENT IS EXPRESSLY PROHIBITED BY GARLOCK HELICOFLEX.